

Linear Diaphragm Pumps LP-150HN, LP-200HN

Flow at rated pressure

150 to 200 l/min at 200 mbar

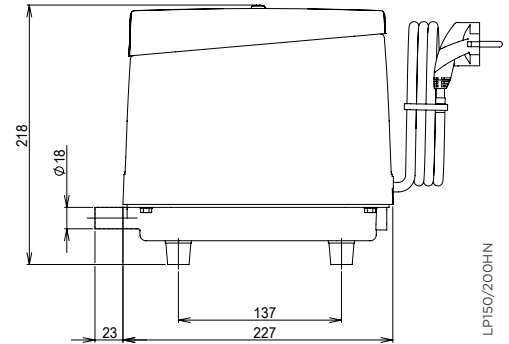
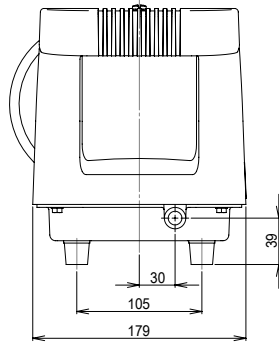

LP150/200HN

PNEUMATIC DATA

Description	LP-150HN	LP-200HN
Part number	52500151	52500202
Flow at rated pressure	150 l/min	200 l/min
Rated pressure	200 mbar	200 mbar
Operating range	100 to 300 mbar	100 to 300 mbar

ELECTRICAL DATA

Motor type	Linear drive	Linear drive
Nominal Voltage	230V 50Hz	230V 50Hz
Consumption at rated pressure	0.85 A/130 W	1.15 A/200 W

GENERAL DATA

Ambient temperature	-10 to 40 °C	-10 to 40 °C
Weight	8.6 kg	8.6 kg
Outlet diameter	18 mm	18 mm
Average sound level	43 dB (A)	44 dB (A)

SERVICE PARTS

Chamber block set ¹⁾	700549	700549
Air filter and gasket kit	700550	700550
Air filter kit	700551	700551
Protective switch ¹⁾	700552	700552

All listed values are measured at standard atmospheric conditions.

If 230V 60Hz is required, consult factory

1) Denotes that service part is only available for trained service personnel.

Please refer to the operation manual for additional information.

FLOW CURVES

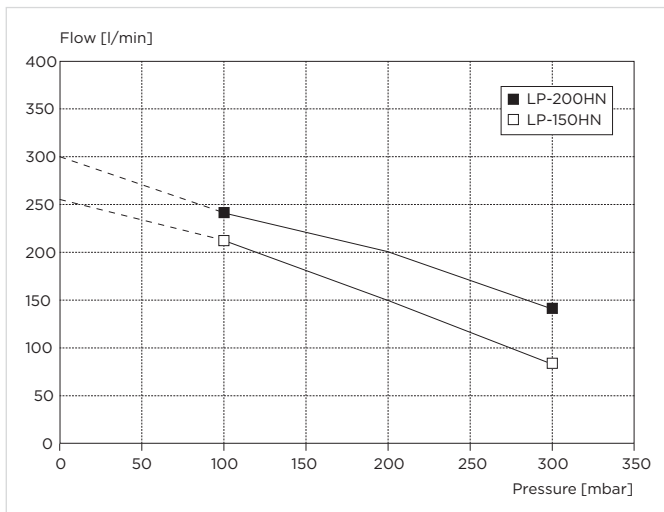

Note: Operation outside specified operating range is not recommended.
All listed values are measured at standard atmospheric conditions

SERVICE PARTS

Chamber block set¹⁾ consists of:
 2 x Pump head with valves
 2 x Diaphragm assembly
 2 x Diaphragm nut
 2 x Diaphragm washer

Air filter and gasket kit consists of:
 1 x Air cleaner element
 1 x Air cleaner gasket
 1 x Cover plate gasket
 1 x Noise absorbing net
 1 x Tank gasket
 2 x L-Hose
 2 x L-Clamp

Air filter kit consists of:
 5 x Air cleaner element
 5 x Air cleaner gasket

Protective switch¹⁾ consists of:
 1 x Microswitch complete with cover plate
 1 x Cover plate gasket

SUPPLIED AS STANDARD

Cable/Euro-plug
 Air connector (part number 700073) consists of:
 1 x Outlet hose, angled, 170/50 mm
 2 x Hose clamp

5250... Stock programme